

Maglev Instructions

General

This is a proof of concept exercise. You will build a small, not very pretty version of a moving part to use in your city model. This is called a Proof of Concept or POC. It gives you experience in working with the materials. You also have parts to make a larger version. For the maglev you will have enough magnets to build a very long maglev or several shorter ones. Cardboard and wood were used because they were available and were otherwise going to be thrown away or put in recycle. Some ideas for other materials

WARNING

The magnets are brittle. They may break if dropped or allowed to slam together. They will leave metal dust on your hands. You must wash your hands after the workshop so you do not ingest any of the dust.

A stack of magnets has a very strong magnetic field, it will pull metal objects from across the table, especially other magnets. Pay attention to where you place magnets and metal objects around them, like scissors.

All of the parts and supplies you need are in your team's brown bag or on the table. Leave scissors and tape on the table when you leave the room. Review the Parts List and Receipt before starting the exercise.

The magnets all have dimples on the N side of the magnet. **Attention to polarity is required** to make the maglev work.

The bag contains 33 magnets, some paperboard and these instructions. On the table there is a 24" piece of wood and two pieces of clear acrylic that will be the maglev track. and a 3.5" piece of wood that will become the maglev engine. The magnets have a dimple on the N pole side. For the Maglev to work all of the magnets need to be oriented correctly. If you accidentally place a magnet incorrectly, you can pry it off and reset. Ask for help if needed, the engineer in the room will have additional tools to make removal easier.

Before you start look at the sample maglev displayed on a table near you.

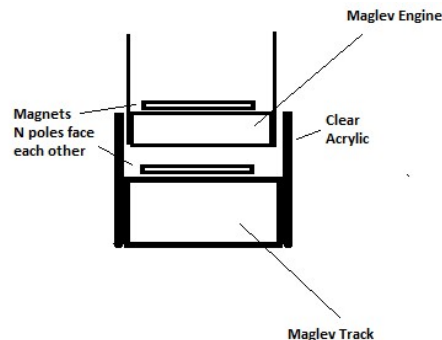

1. Build the Maglev Tracks

1.1. Parts needed

- 1" x 0.75" x 24" Wood base
- 2 pieces of 24" x 1.5" clear acrylic
- 30 magnets

- 1.2. Using double sided tape, fasten 30 magnets to the wide side of the 24" piece of wood. Take care to make sure the N pole (the side with the dimple) facing upward on all of them. The train is more stable if they are alternately aligned with the sides of the wood. See diagram

- 1.3. Hold a magnet with the N side down over the



magnets. If it pulled down anywhere, then there is a magnet installed upside down.

- 1.4. Peel the protective layers off of both sides of the clear acrylic pieces.
- 1.5. Using double sided tape fasten the clear acrylic pieces of the 24" long piece of wood. The bottoms of the acrylic pieces should be flush with the bottom of the wood.

Maglev Instructions

2. Assemble Maglev Engine

2.1. Parts needed:

7/8"x3.5"x0.5" Plywood

2 or 3 Magnets

Paperboard (cereal box material)

In addition, you will have to use some of the double-sided tape and the scissors on the table.

- 2.2. Using double sided tape, fasten the magnets **N side down** to the 7/8" x 3.5" piece of plywood. Take care to get the magnets exactly centered. See diagram. Looking down on the engine you will not see the dimples.
- 2.3. Test the maglev engine and adjust as needed.
- 2.4. Cut the paperboard to make a top for the engine. See the display sample. You will probably need 3 pieces, but be creative. A 3.5" length of double-sided tape cut it in half lengthwise will hold the paperboard to the sides of the wood engine.

3. Test maglev

- 3.1. Slide the maglev Train into the channel of the Maglev tracks. It should float and barely touch the side pieces of cardboard. Lightly tap one end of the train, it should float to the other end. Send it back

3.2. Trouble shooting.

3.2.1. Train Drags on the side pieces of the track

Lightly press on the side pieces acrylic to push them wider.

Test the train again.

Repeat until it floats freely.

3.2.2. Train flips over

Magnets on engine not installed correctly. Check the sample displayed and diagrams.

3.2.3. Train is pulled down to the tracks

One or more of the magnets have the wrong polarity. You should see the dimples on all of the magnets. If you don't then the magnet was placed upside down. Pry it off and reset it correctly.

4. Make the Maglev better – you might have enough time to try some of these at the Engineering Fair

- 4.1. Create another engine with a tube that could be a water tank to carry water. Extra wood and magnets are available for the asking. Note that putting a heavier load on the engine will change the height at which the engine floats and the balance.
- 4.2. Use creative shape, color and design for the train, color helps
- 4.3. Use a blast of air to get it moving without touching it
- 4.4. Set it at an angle to roll down hill
- 4.5. An electromagnet placed at just the right location at the end of the track might work to get the train going without touching it.

Maglev Instructions

Parts List and Receipt for Parts

Source for magnets www.amazon.com/gp/product/B01MU5GO36/

You will need to include the cost of magnets and acrylic used in your model on the expense form for the competition if you incorporate the maglev.

| | Unit Cost | Measure | Total per Team | Cost |
|--|-----------|---------|----------------|---------------|
| Round Magnets with North Pole Marking - Ceramic Thin Magnets - Craft Magnets Size is 22 mm (7/8) | \$0.10 | each | 33 | \$3.30 |
| Acrylic 24" x 1.5" | \$1.78 | Each | 2 | \$3.56 |
| 7/8"x3.5"x0.5" Plywood | \$0.00 | | 1 | \$0.00 |
| 1"x x 0.75" x 24" Wood base | \$0.00 | | 1 | \$0.00 |
| Spare Paperboard or cardboard for engine model | \$0.00 | | 2 | \$0.00 |
| Double Sided Tape | | | | |
| Total | | | | \$6.86 |

Train Right Side:



Train Left Side:

